

Technical data

Technical data	U.M.	AxBxH
Bread Moulder 500/600		
External dimensions 500 (trays opened)	mm	1410x748x1181
External dimensions 500 (trays closed)	mm	970x748x1181
External dimensions 600 (trays opened)	mm	1410x848x1181
External dimensions 600 (trays closed)	mm	970x848x1181
weight	Kg	135/140
weight with packaging	Kg	165/170
External dimension of packaging	mm	765x960x1440
Rollers size	Ø mm	50
Operating rollers width	mm	500/600
Rollers gap	mm	0-10
Pieces	gr	min.25 / max.1000
Power supply	Kw	1,1
Rated supply voltage	V	220-380
Frequency	Hz	50/60
Electrical phases	n°	1/3
Max number of pieces	Pz./h	1200

Technical drawings

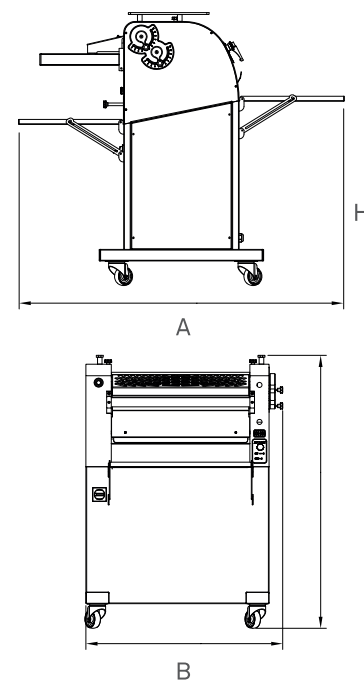

Technical data	U.M.	AxBxH
French Bread Maker		
External dimension	mm	990x780x754
External dimension of packaging	mm	800x1150x1000
weight	Kg	195
support weight (optional)	Kg	15
weight with packaging	Kg	215
pieces	g	from 35 to 1000
operating rollers width	mm	790
power supply	Kw	0.75
rated supply voltage	V	220-380
frequency	Hz	50/60
Max number of pieces	Pz./h	1200

Technical drawings

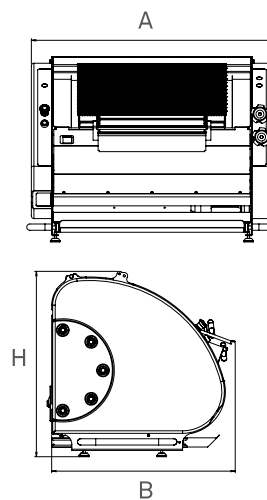

Алматы (7273)495-231
 Ангарск (3955)60-70-56
 Архангельск (8182)63-90-72
 Астрахань (8512)99-46-04
 Барнаул (3852)73-04-60
 Белгород (4722)40-23-64
 Благовещенск (4162)22-76-07
 Брянск (4832)59-03-52
 Владивосток (423)249-28-31
 Владикавказ (8672)28-90-48
 Владимир (4922)49-43-18
 Волгоград (844)278-03-48
 Вологда (8172)26-41-59
 Воронеж (473)204-51-73
 Екатеринбург (343)384-55-89

Иваново (4932)77-34-06
 Ижевск (3412)26-03-58
 Иркутск (395)279-98-46
 Казань (843)206-01-48
 Калининград (4012)72-03-81
 Калуга (4842)92-23-67
 Кемерово (3842)65-04-62
 Киров (8332)68-02-04
 Коломна (4966)23-41-49
 Кострома (4842)77-07-48
 Краснодар (861)203-40-90
 Красноярск (391)204-63-61
 Курск (4712)77-13-04
 Курган (3522)50-90-47
 Липецк (4742)52-20-81

Россия +7(495)268-04-70

Магнитогорск (3519)55-03-13
 Москва (495)268-04-70
 Мурманск (8152)59-64-93
 Набережные Челны (8552)20-53-41
 Нижний Новгород (831)429-08-12
 Новокузнецк (3943)20-46-51
 Новороссийск (3496)41-32-12
 Новосибирск (383)227-86-73
 Омск (3812)21-46-40
 Орел (4862)44-53-42
 Оренбург (3532)37-68-04
 Пенза (8412)22-31-16
 Петрозаводск (8142)55-98-37
 Пермь (8112)59-10-37
 Пермь (342)205-81-47

Казахстан +7(7172)727-132

Ростов-на-Дону (863)308-18-15
 Рязань (4912)46-61-64
 Самара (846)206-03-16
 Санкт-Петербург (812)309-46-40
 Саратов (845)249-38-78
 Севастополь (8692)22-31-93
 Саранск (8342)22-95-24
 Симферополь (3652)67-13-56
 Смоленск (4812)29-41-54
 Сочи (862)225-72-31
 Ставрополь (8652)20-65-13
 Сургут (3462)77-98-35
 Сыктывкар (8212)25-95-17
 Тамбов (4752)50-40-97
 Тверь (4822)63-31-35

Киргизия +996(312)96-26-47

Тольятти (8482)63-91-07
 Томск (3822)98-41-53
 Тула (4872)33-79-87
 Тюмень (3452)66-21-18
 Ульяновск (8422)24-23-59
 Улан-Удэ (3012)59-97-51
 Уфа (347)229-48-12
 Хабаровск (4212)92-98-04
 Чебоксары (8352)28-53-07
 Челябинск (351)202-03-61
 Череповец (8202)49-02-64
 Чита (3022)38-34-83
 Якутск (4112)23-90-97
 Ярославль (4852)69-52-93

Bread moulder

French bread and italian bread

MADE IN ITALY

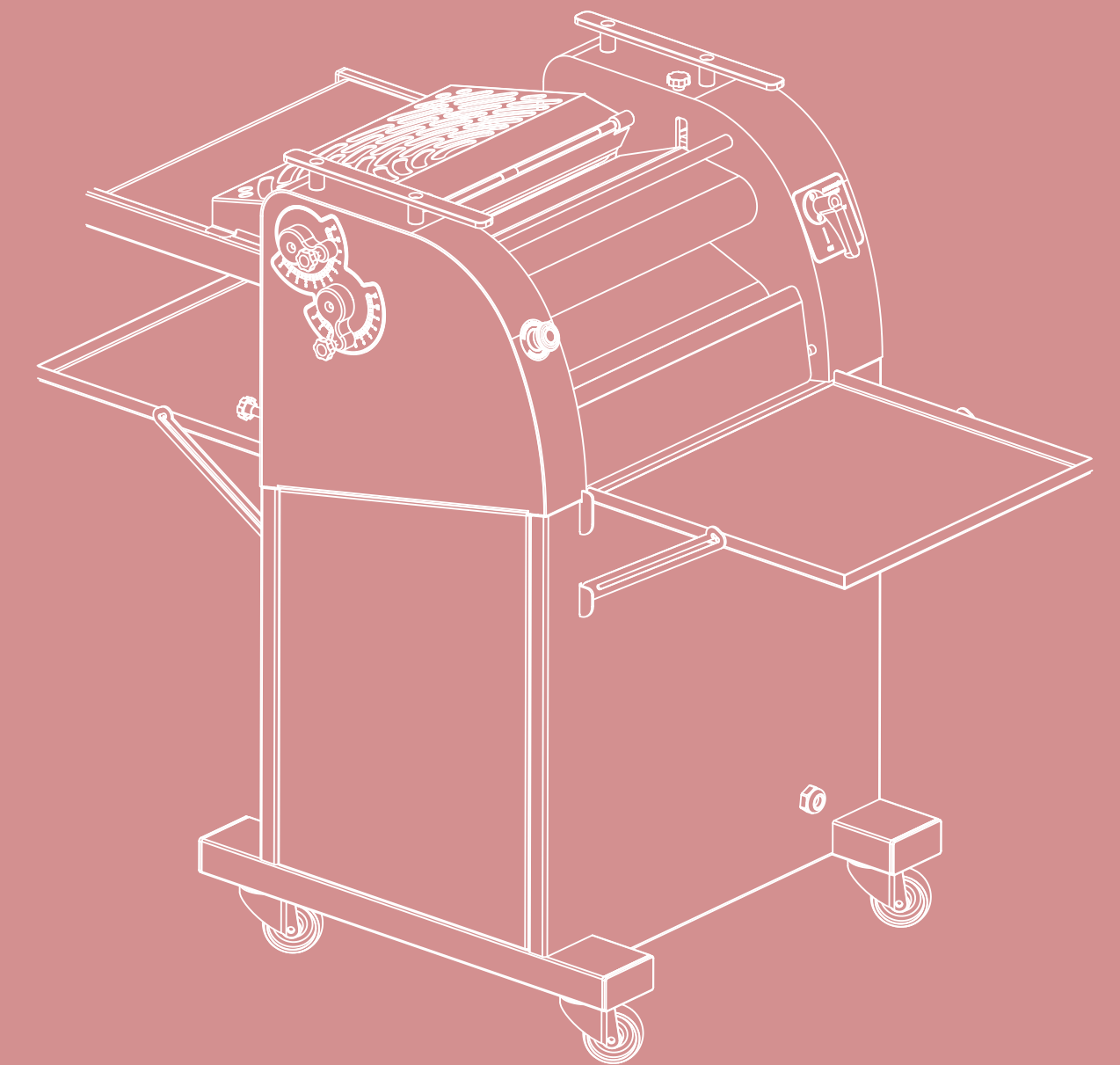

Tekno Stamap reserves the right to make technical changes at any time and without notice..

<https://teknostamap.nt-rt.ru/> || tpd@nt-rt.ru

1982
40 Tekno
 2022 Stamap

Technology boosting creativity

EN

Bread Moulder

French bread and italian bread

SHAPE AND SUBSTANCE

Bread Moulder

Tekno Stamap bread moulder machine has been designed to be: practical thanks to the possibility of letting the product come out both from the front and the back; robust thanks to the mechanisms in aluminum casting; reliable with all the mechanics parts mounted on bearings and practical as the rollers of towing and wrapping belts have been designed to be easily replaced and cleaned. The ease of adjustment will allow you to create the desired shapes of bread in the shortest possible time, with a high production efficiency.



To make Italian bread like rosette, turtles and clogs or french baguettes.

French Bread Maker

Its particularly attractive design makes this equipment a style reference for future productions combining design with efficiency and ease of use, adjustment and cleaning. It allows the production of up to 1200 pieces per hour, with a maximum baguette length of up to 700 millimeters. In rest position the machine can be closed resulting less bulky and limiting the visual impact. The structure of the machine is in stainless steel and all the parts in contact with the product are non-toxic.

Bread Moulder

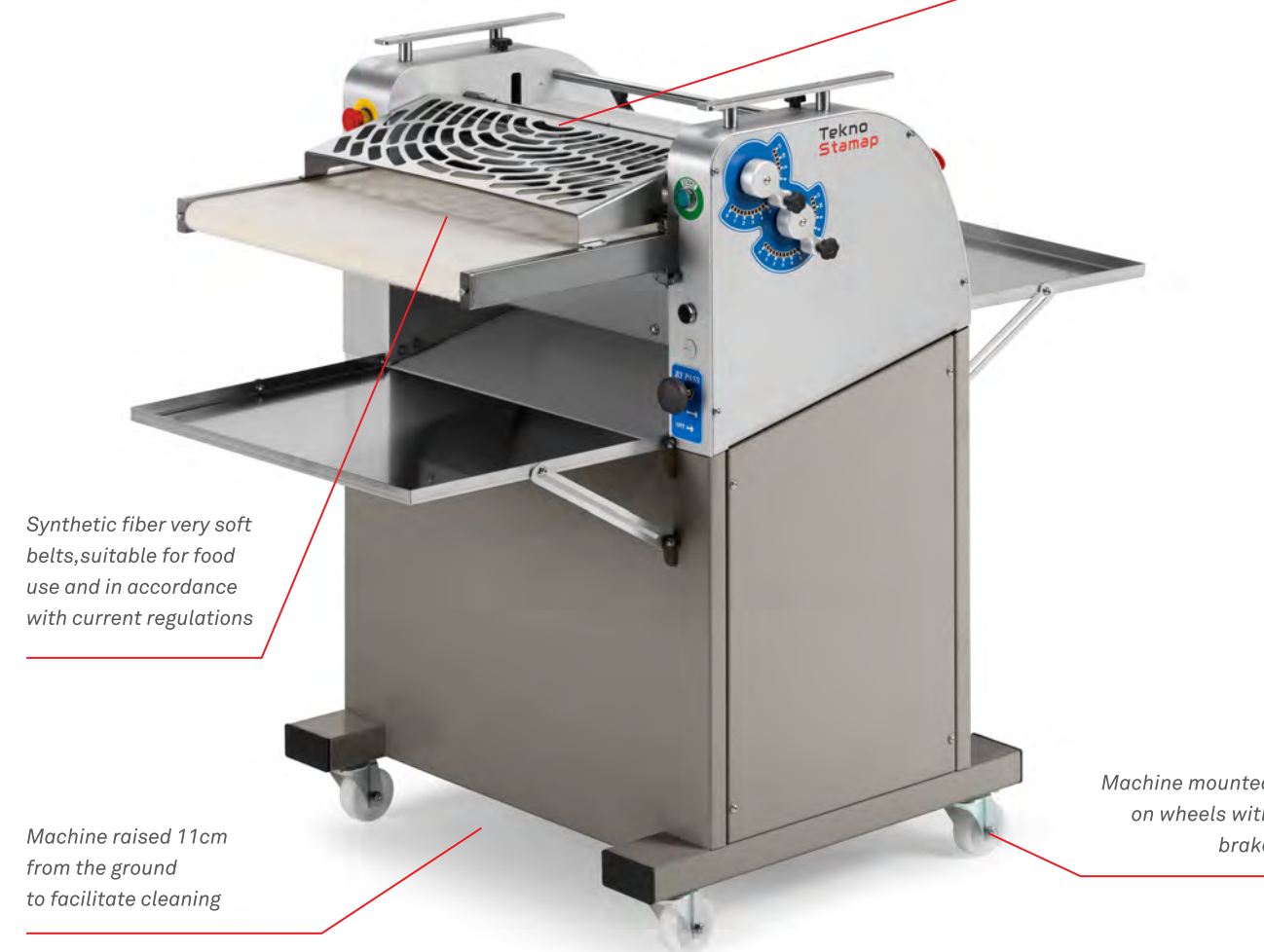

Synthetic fiber very soft belts, suitable for food use and in accordance with current regulations

Machine raised 11cm from the ground to facilitate cleaning

Machine mounted on wheels with brake

The possibility to lock the top carpet allows you to use the moulder as flattener to produce for example pizza, Arabic bread and wraps

French baguette moulder



Rollers in synthetic material for food use, mounted on removable frames and therefore easily washable

Optional: trolley on wheels with brake to lift the machine

Front controls to approach the machine to other machines or to the wall

Maximum useful rolling length 790 mm



OPTIONAL

Loaf maker to form elongated bread or loaves, equipped with an adjustable table to adapt to any type of need.

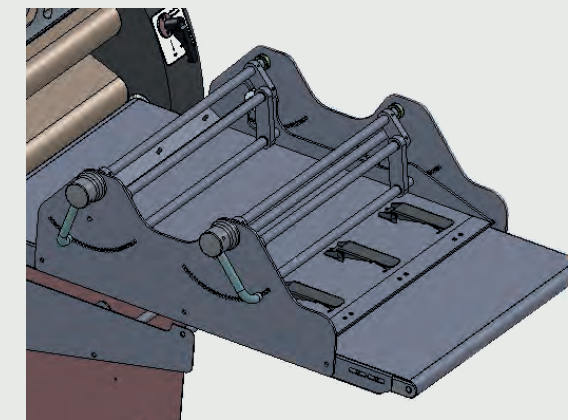

TECHNICAL DETAILS

Rollers in acetal resin for intensive use and for laminating even very hard dough. Scrapers with spring support, removable and washable without the use of tools. Roller diameter 89 mm.



Алматы (7273)495-231
Ангарск (3955)60-70-56
Архангельск (8182)63-90-72
Астрахань (8512)99-46-04
Барнаул (3852)73-04-60
Белгород (4722)40-23-64
Благовещенск (4162)22-76-07
Брянск (4832)59-03-52
Владивосток (423)249-28-31
Владикавказ (8672)28-90-48
Владимир (4922)49-43-18
Волгоград (844)278-03-48
Вологда (8172)26-41-59
Воронеж (473)204-51-73
Екатеринбург (343)384-55-89

Иваново (4832)77-34-06
Ижевск (3412)26-03-58
Иркутск (395)279-98-46
Казань (843)206-01-48
Калининград (4012)72-03-81
Калуга (4842)92-23-67
Кемерово (3842)65-04-62
Киров (8332)68-02-04
Коломна (4966)23-41-49
Кострома (4842)77-07-48
Краснодар (861)203-40-90
Красноярск (391)204-63-61
Курск (4712)77-13-04
Курган (3522)50-90-47
Липецк (4742)52-20-81

Россия +7(495)268-04-70

Магнитогорск (3519)55-03-13
Москва (495)268-04-70
Мурманск (8152)59-64-93
Набережные Челны (8552)20-53-41
Нижний Новгород (831)429-08-12
Новокузнецк (3843)20-46-81
Новосибирск (383)227-86-73
Новосибирск (383)227-86-73
Омск (3812)21-46-40
Орел (4862)44-53-42
Оренбург (3532)37-68-04
Пenza (8412)22-31-16
Петрозаводск (8142)55-98-37
Псков (8112)59-10-37
Пермь (342)205-81-47

Казахстан +7(7172)727-132

Ростов-на-Дону (863)308-18-15
Рязань (4912)46-61-64
Самара (846)206-03-16
Санкт-Петербург (812)309-46-40
Саратов (845)249-98-78
Севастополь (8692)22-31-93
Саранск (8342)22-96-24
Симферополь (383)227-86-73
Смоленск (4812)29-41-54
Сочи (862)225-72-31
Ставрополь (8652)20-65-13
Сургут (3462)77-98-35
Сыктывкар (8212)25-95-17
Тамбов (4752)50-40-97
Тверь (4822)63-31-35

Киргизия +996(312)96-26-47

<https://teknoStamap.nt-rt.ru/> || tpd@nt-rt.ru